



# OPERATION, PARTS AND SAFETY MANUAL

## DSA-250 MANUAL SEALER

Part No. 00414.98

### GENERAL SAFETY CONSIDERATIONS

- EYE INJURY HAZARD.**  
Failure to wear safety glasses with side shields can result in severe eye injury or blindness. Always wear safety glasses with side shields which conform to ANSI Standard Z87.1 or EN 166.
- FALL HAZARD.**  
Maintaining improper footing and/or balance when operating the tool can cause you to fall. Do not use the tool when you are in an awkward position.
- CUT HAZARD.**  
Handling strap or sharp parts could result in cut hands or fingers. Wear protective gloves.
- TRAINING.**  
This tool must not be used by persons not properly trained in its use. Be certain that you receive proper training from your employer. If you have any questions contact your Acme Representative.
- TOOL CARE.**  
Take good care of the tool. Inspect and clean it daily, lubricate it weekly. Replace any worn or broken parts.
- WORK AREA.**  
Keep work areas uncluttered and well lighted.
- TENSIONING STRAP.**  
When tensioning strap use proper tensioner for specific strap sizes. Read the tensioner's operation and safety manual.

Several combinations of strap, seals and tools can be used with this sealer. Use the correct Acme products for your application. If you need help contact your Acme Representative.

### SAFETY PROCEDURES FOR TOOL OPERATION

- Before using this sealer, read all the instructions in this Operation, Parts and Safety Manual.
- Always lift and carry the tool by the tool handle knob. Lifting the tool at any other point may expose the hand to a "pinch point."
- Make sure the sealer jaws are placed directly on the seal.
- While sealing, position yourself to one side of the tensioned strap.
- This tool is a single notch-type sealer that requires two sealing operations for each seal. A properly notched seal will appear as shown in the illustrations below. Each notch should be placed no less than 3/16" from the seal edge. If the notched seal does not appear as shown, inspect the tool for worn and/or damaged parts. Replace tool parts as needed. Do not ship any loads secured with improperly notched seals. Seal must be properly notched.

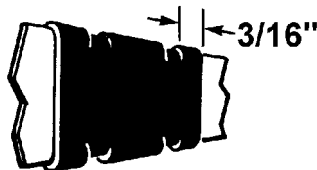

### CUTTING TENSIONED STRAP

**FLYING STRAP HAZARD.** Using claw hammers, crowbars, chisels, axes or similar tools will cause tensioned strap to fly apart with hazardous force. Use only cutters designed for cutting strap. Read the instructions in the cutters manual for proper procedure in cutting strap. Before using any Acme product read its operation and safety manual.

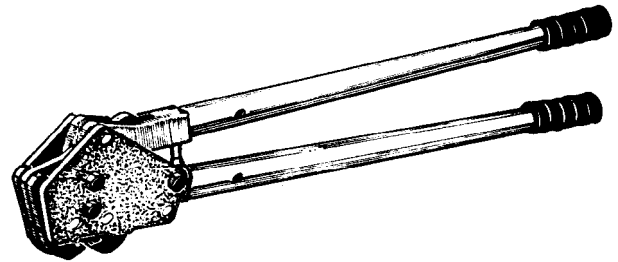

### SPECIFICATIONS

For use with 2" wide high tensile steel strap, .044" to .050" thick.

This tool uses the following seals: 203, 208

### OPERATING INSTRUCTIONS

- Fully open the sealer handles and place the open jaws to one end of the seal.

FIGURE-1

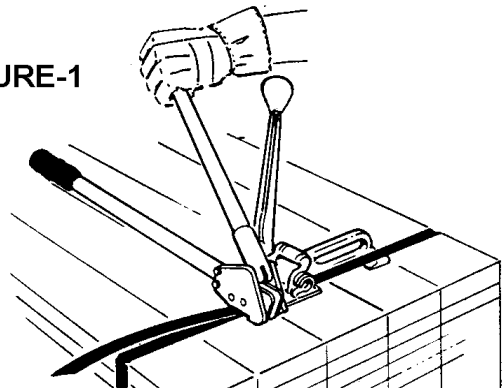

## OPERATING INSTRUCTIONS, Continued

2. Bring the sealer handles completely together to assure a proper notch.
3. Remove the sealer. Place the sealer on the opposite end of the seal and apply the remaining notch by bringing the handles completely together. Remove the sealer when through.

**NOTE:** If the gauge of the strap being used will not allow it to be bent, cut the strap supply as close to the seal as possible using an approved strap cutter.

4. To avoid contact with the sharp end of the strap, retract the strap end back into the strap dispenser.

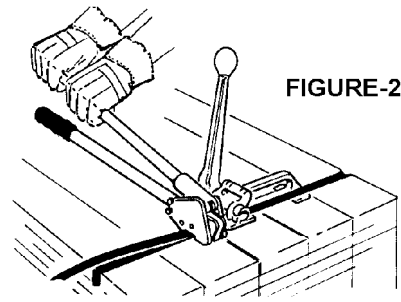

## PARTS LIST

KEY	QTY.	PART#	DESCRIPTION	KEY	QTY.	PART#	DESCRIPTION
1	3	003868	Flexloc nut, thin, 3/8-24	12	1	020522	<u>Holding pawl</u>
2	2	020534	<u>Side plate</u>	13	1	020523	<u>Locking pawl</u>
3	5	020528	<u>Pivot pin</u>	14	1	020532	<u>Lock pawl spring</u>
4	1	020533	<u>Holding pawl pin</u>	15	1	020527	<u>Long link</u>
5	1	020535	<u>Upper handle assembly</u>	16	1	020526	<u>Short link</u>
6	4	013152	Jaw	17	3	020540	Hex head cap screw, 3/8-24 x 2
7	4	020536	Spacer	18	2	423361	Handle grip
8	1	013151	Notcher	19	1	020525	Handle assembly
9	1	020531	Pawl spring	20	1	003132	Caution plate
10	1	006787	Roll pin, 3/16 x 1	21	1	423359	Nameplate
11	4	020529	<u>Link pin</u>				

When ordering parts, please show tool model, part number and name. All recommended spare parts are underlined and should be stocked. Standard hardware parts may be obtained from local hardware suppliers.

For Parts Support Call 1-800-541-5736

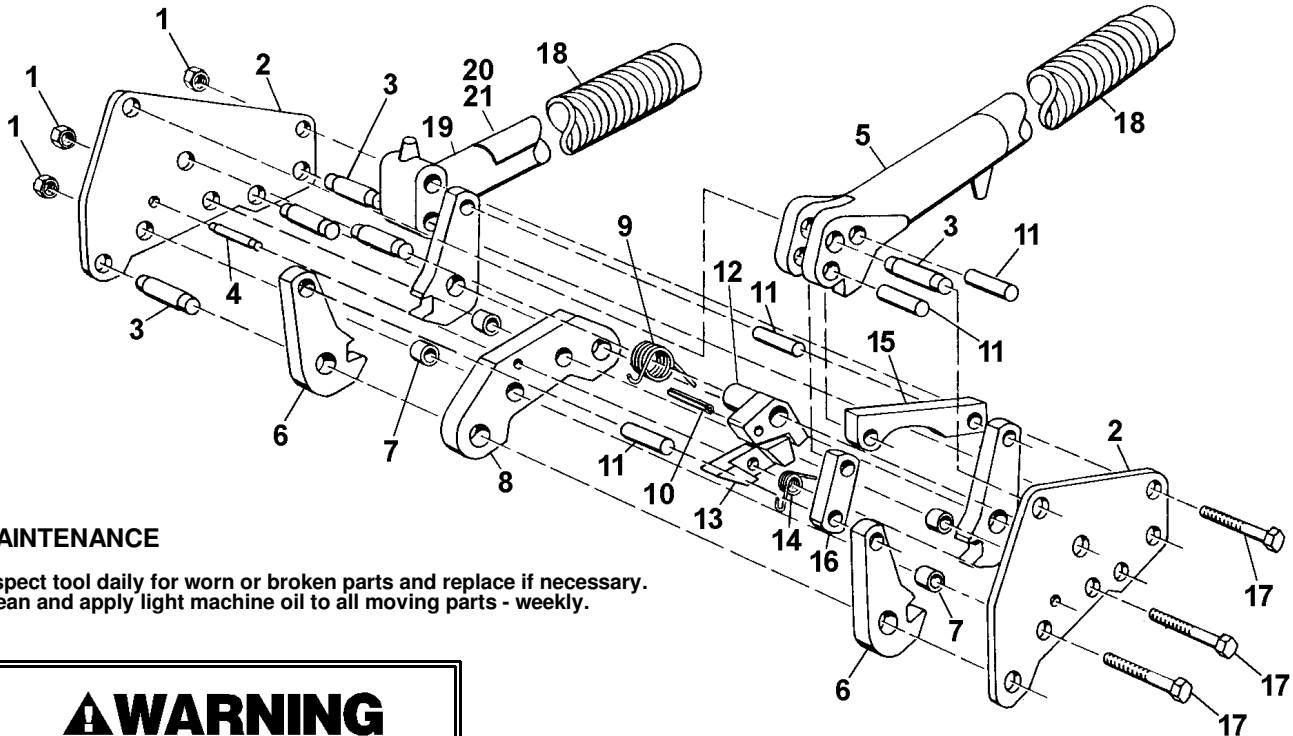

## MAINTENANCE

Inspect tool daily for worn or broken parts and replace if necessary.  
Clean and apply light machine oil to all moving parts - weekly.

## **▲WARNING**

Inspect all parts daily and replace them if they are worn or broken. Failure to do this can affect a product's operation and could result in serious personal injury.