

MIP - 1300 STEEL STRAP TENSIONER

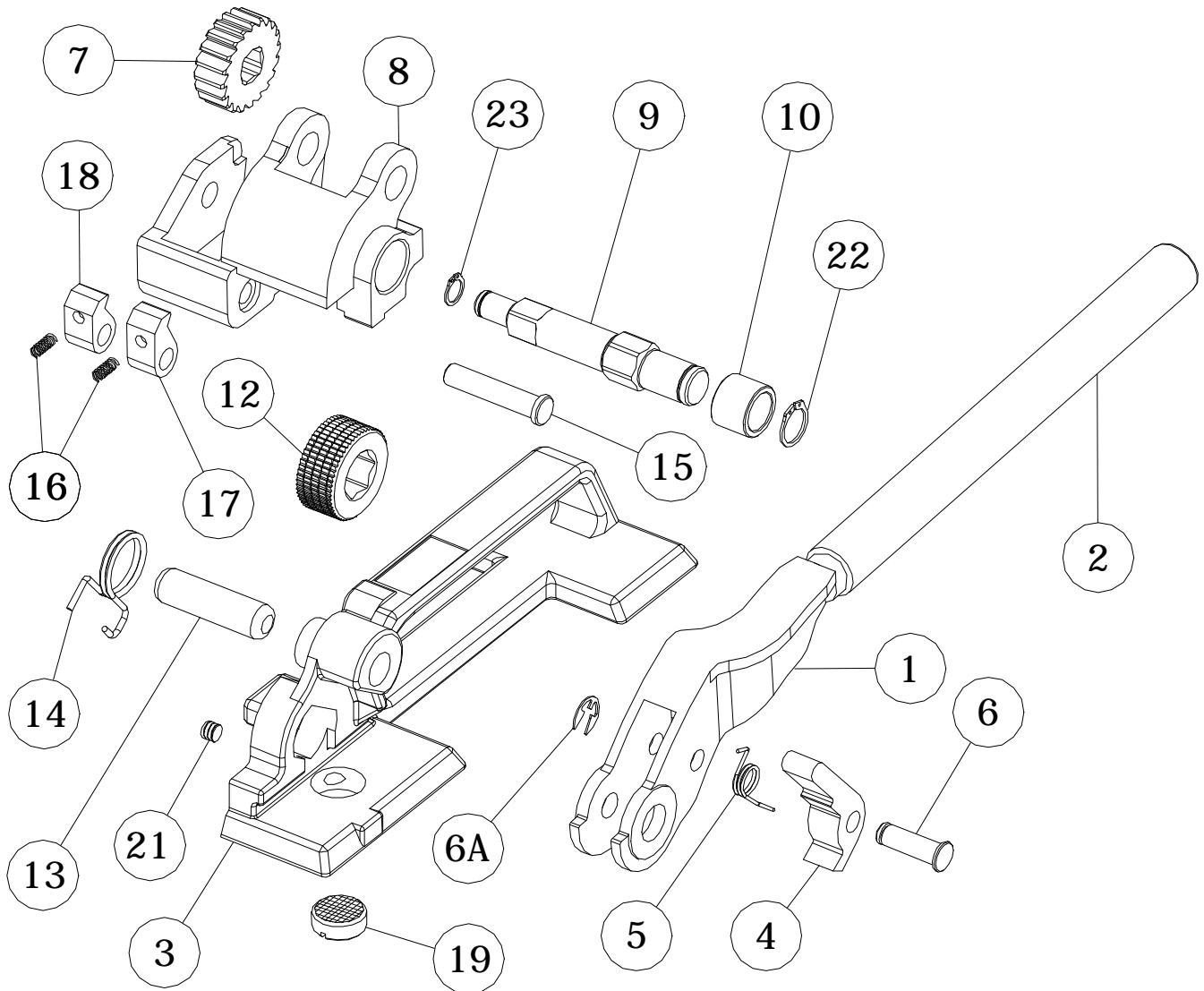

KEY#	DESCRIPTION	QTY	PART#
1	Handle Assembly	1	M1300-1
2	Handle Grip	1	M1300-2
3	Base	1	M1300-3
• 4	Handle Pawl	1	M1300-4
• 5	Handle Pawl Spring	1	M1300-5
6	Crosshead Pin	1	M1300-6
• 6A	Retaining Ring	1	M1300-6A
• 7	Ratchet Gear	1	M1300-7
8	Support Frame	1	M1300-8
9	Shaft	1	M1300-9
• 10	Bushing	1	M1300-10

KEY#	DESCRIPTION	QTY	PART#
• 12	Feedwheel	1	M1300-12
• 13	Support Pin	1	M1300-13
• 14	Support Frame Spring	1	M1300-14
• 15	Retaining Pawl Pin	1	M1300-15
• 16	Pawl Spring	2	M1300-16
• 17	Long Pawl	1	M1300-17
• 18	Short Pawl	1	M1300-18
• 19	Clutch Plug	1	M1300-19
• 21	Clutch Plug Set Screw	1	M1300-21
• 22	Retaining Ring - Large	1	M1300-22
• 23	Retaining Ring - Small	1	M1300-23

Reference part number when ordering.

- **Key wear part**

Read all operating & safety instructions.

MIP-1300 OPERATING INSTRUCTIONS

OPERATING INSTRUCTIONS:

1. Pull the loose end of the strap all the way around the package and bring it under the other end of the strapping. Be sure to keep the strap snug about the package and squarely in line.
2. Holding the strap in place with the left hand, take the tool in the right hand and squeeze the handle (Key #1) down to the base (Key #3). Slide the tool under the strap such that strap passes between the feedwheel and clutch plug (Key #12 and #19). Be sure that the strap is up against the inner edge of the tool, that the back foot of the base is on top of the strap, and that the loose end of strap is still on the bottom and facing the back of the tool. (See illustration.)
3. With the edges of the strap aligned with the inside edge of the MIP-1300, tension the strapping by moving the handle back and forth.

WARNING: While tensioning, be sure NOT to bring the handle all the way back down to the base. Doing so will cause the feedwheel to rise and release the tensioned strap.

4. Snap a seal over both pieces of strapping directly in front of the tensioner and crimp with an appropriate steel strap sealer, according to sealer manufacturer's instructions.
5. With the seal securely in place, press the handle pawl (Key #4) with the right thumb, and use the right hand to squeeze the handle down the base, raising the feedwheel. In this position, remove the MIP-1300 by sliding the back foot out to the side, followed by the front.
6. Using approved strap cutters, cut the excess strap as close to the seal as possible.

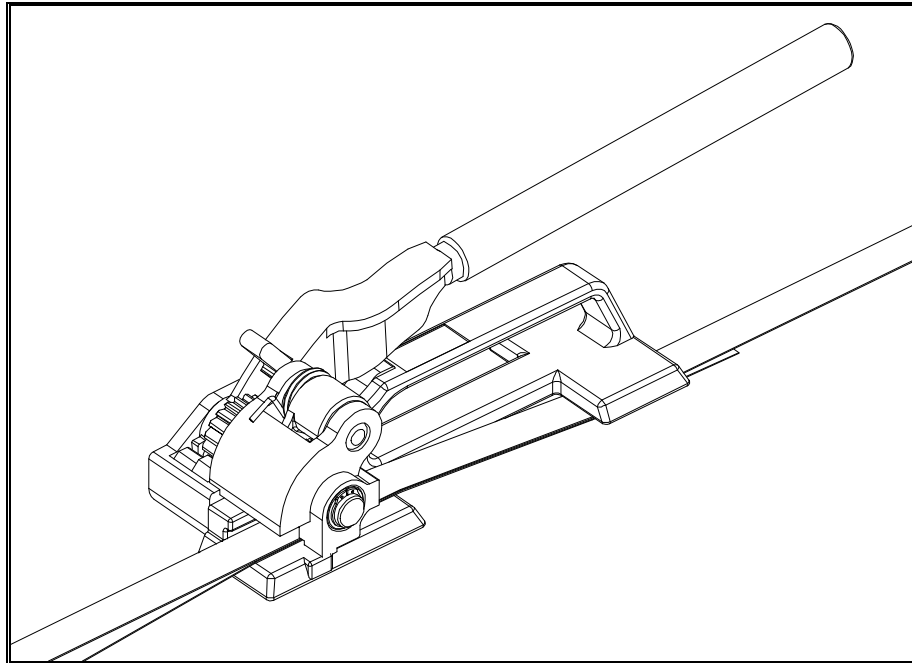

SAFETY WARNINGS:

- Before operating the tool, review the enclosed MIP, Inc. General Hand Tools and Strapping Safety booklet. Only trained personnel should operate MIP, Inc. hand tools.
- Keep fingers away from areas that can pinch or cut. These areas are primarily located at the front of the tool.
- Dangerous breakage may occur due to excessive tensioning, possibly resulting in severe injury or death. Tension strap in moderation.
- Only use equipment recommended for the strap. The MIP-1300 is recommended only for 3/8" x .015 through 3/4" x .025 gauge steel strap.
- Review the instructions and safety material on a regular basis.
- **Warning:** Unsafe use may result in blindness, severe laceration, amputation, or death.